



MANUAL DE INSTALACIÓN

Sistema de Enganche Reforzado ST5 SE093

Renault Master 2.3 DCI
Furgón L1H1 - L2H2 - L3H2 2013+

1 CONTENIDO

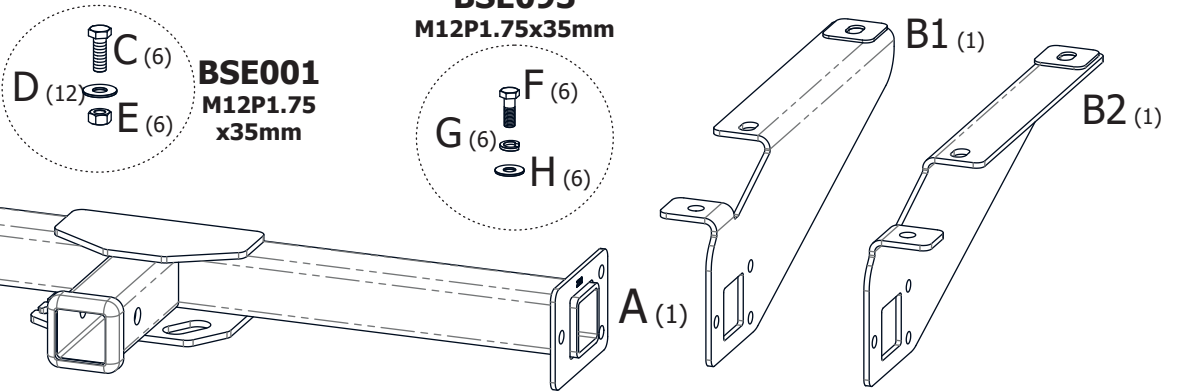

2 HERRAMIENTAS NECESARIAS

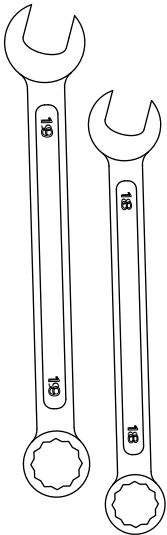

COLOCACIÓN DE PIEZAS "B1" Y "B2"

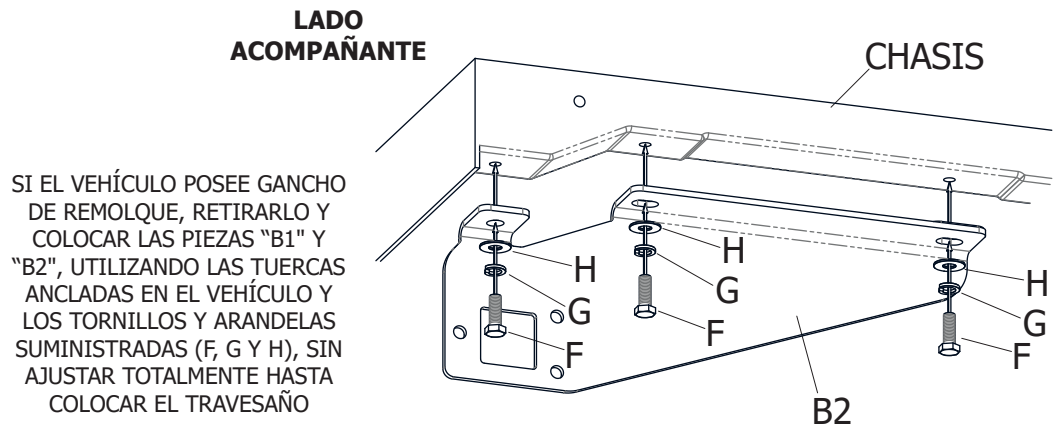

3 COLOCACIÓN DE PIEZAS "A", "I" Y "J"

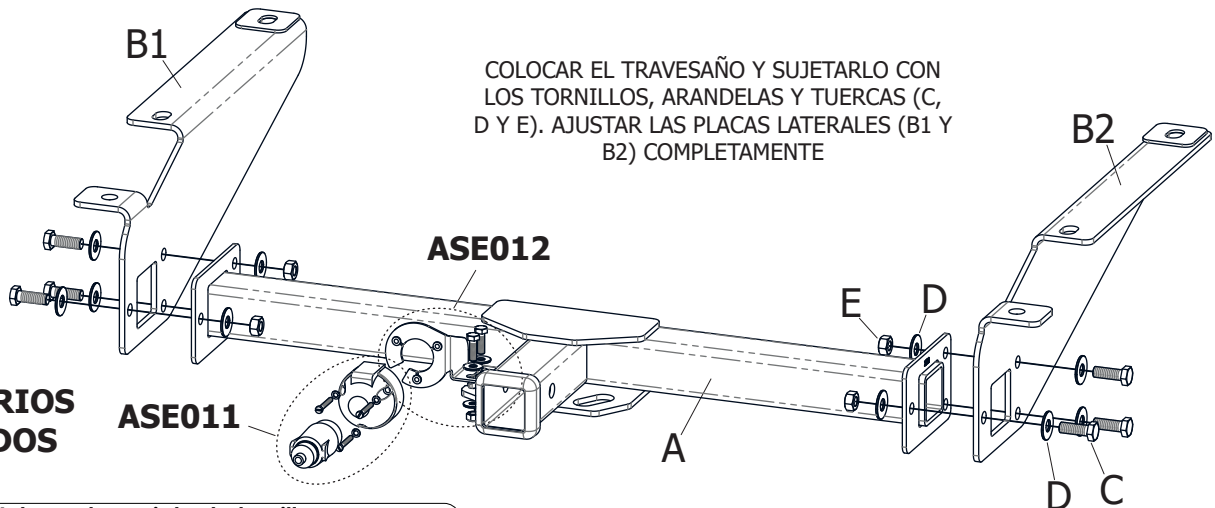

ACCESORIOS SUGERIDOS

ASE011

ASE012

Valores de apriete de tornillos						
Unidades	M4	M6	M8	M10	M12	M14
Kg.m	0,3	1	2,5	5,1	8,7	14
Coeficiente de fricción: $\mu=0,14$						